

REVISIONS				
REV.	DESCRIPTION	DATE	DWG NO	APPROVED
A	LOGO CHANGED	5/24/2007		

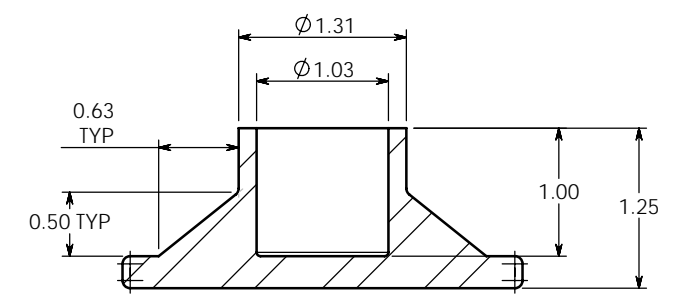
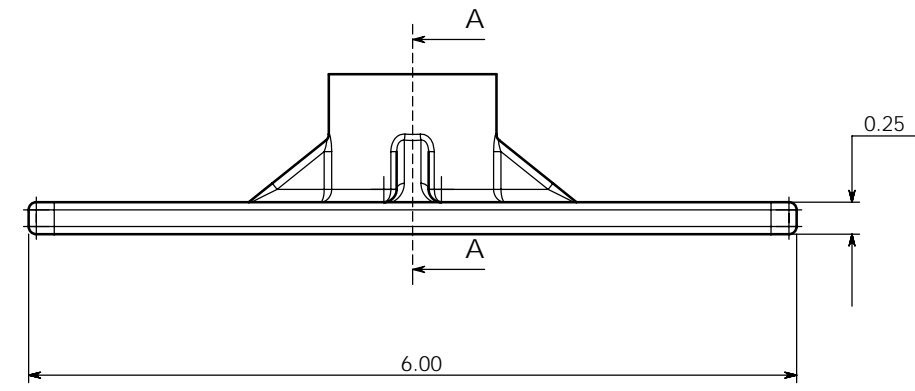
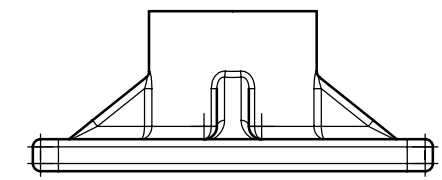
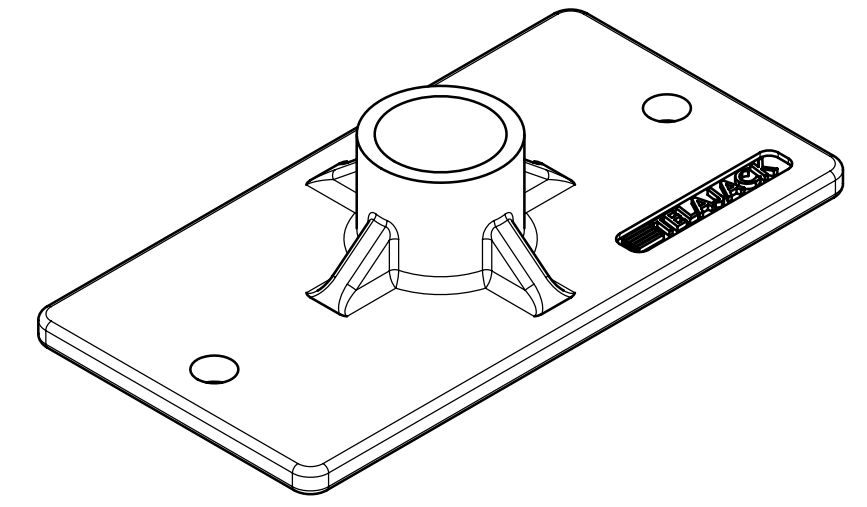
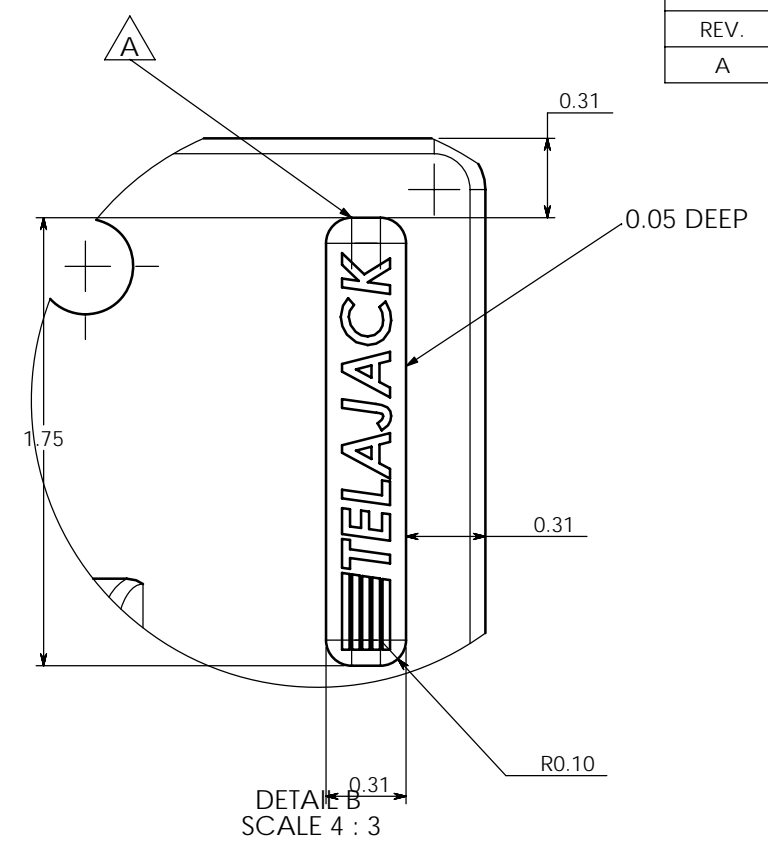
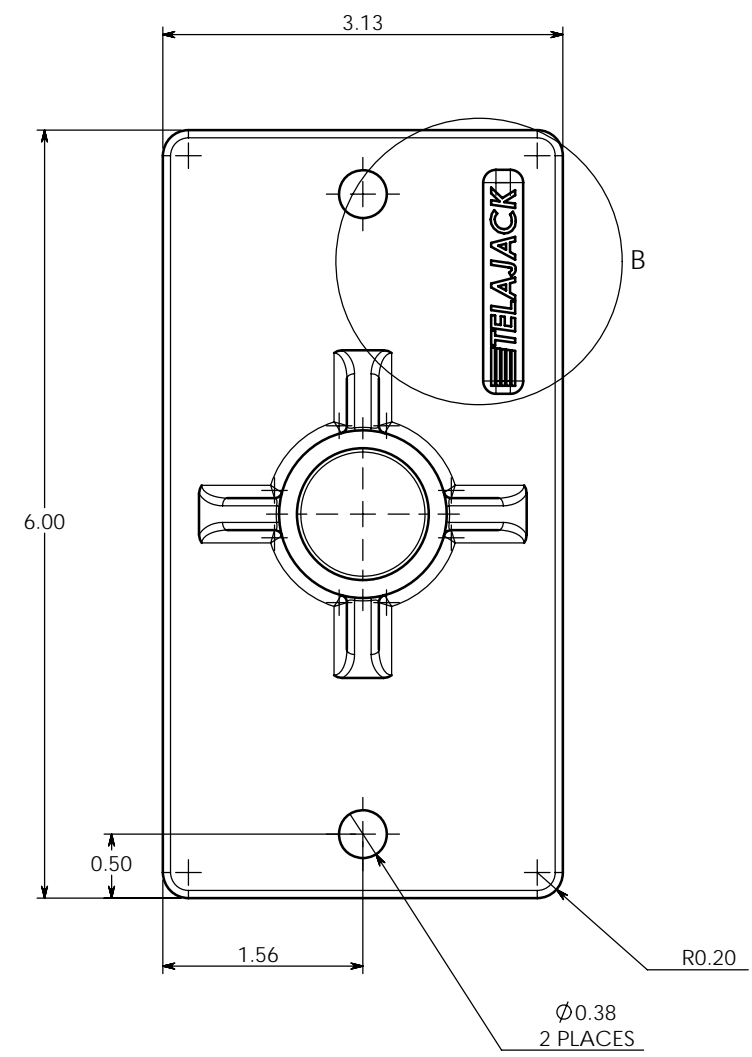

SECTION A-A  
SCALE 2 : 3

**PROPRIETARY AND CONFIDENTIAL**

THE INFORMATION CONTAINED IN THIS DRAWING IS THE SOLE PROPERTY OF TELAJACK LLC. ANY REPRODUCTION OR DISTRIBUTION IN PART OR AS A WHOLE WITHOUT THE WRITTEN PERMISSION OF TELAJACK LLC IS PROHIBITED

**UNLESS OTHERWISE SPECIFIED:**

DIMENSIONS ARE IN INCHES

**TOLERANCES:**

FRACTIONAL	$\pm 1/32"$
ANGLE	MACH $\pm 0.25^\circ$ BEND $\pm 0.5^\circ$
TWO PLACE DECIMAL	$\pm 0.03"$
THREE PLACE DECIMAL	$\pm 0.010"$

DATE:	2007.03.28	NAME:	A BUTLER	CUSTOMER:	PCT
DRAWN:				PART NO:	02
CHECKED:				DESCRIPTION:	TOP PLATE
ENG APPR:				MATERIAL:	1020 OR EQUIV
MFG APPR:				FINISH:	125
QA APPR:				QUANTITY:	AS PER RFQ
COMMENT:	ALL RADS 0.06 UNLESS MARKED				

**TELAJACK**

DRAWING NO:  
**RFQ01-C-02-REV A**

WEIGHT: 1.50 LBS      ISSUED: 12/31/2007