

REVISIONS				
REV.	DESCRIPTION	DATE	DWG NO	APPROVED

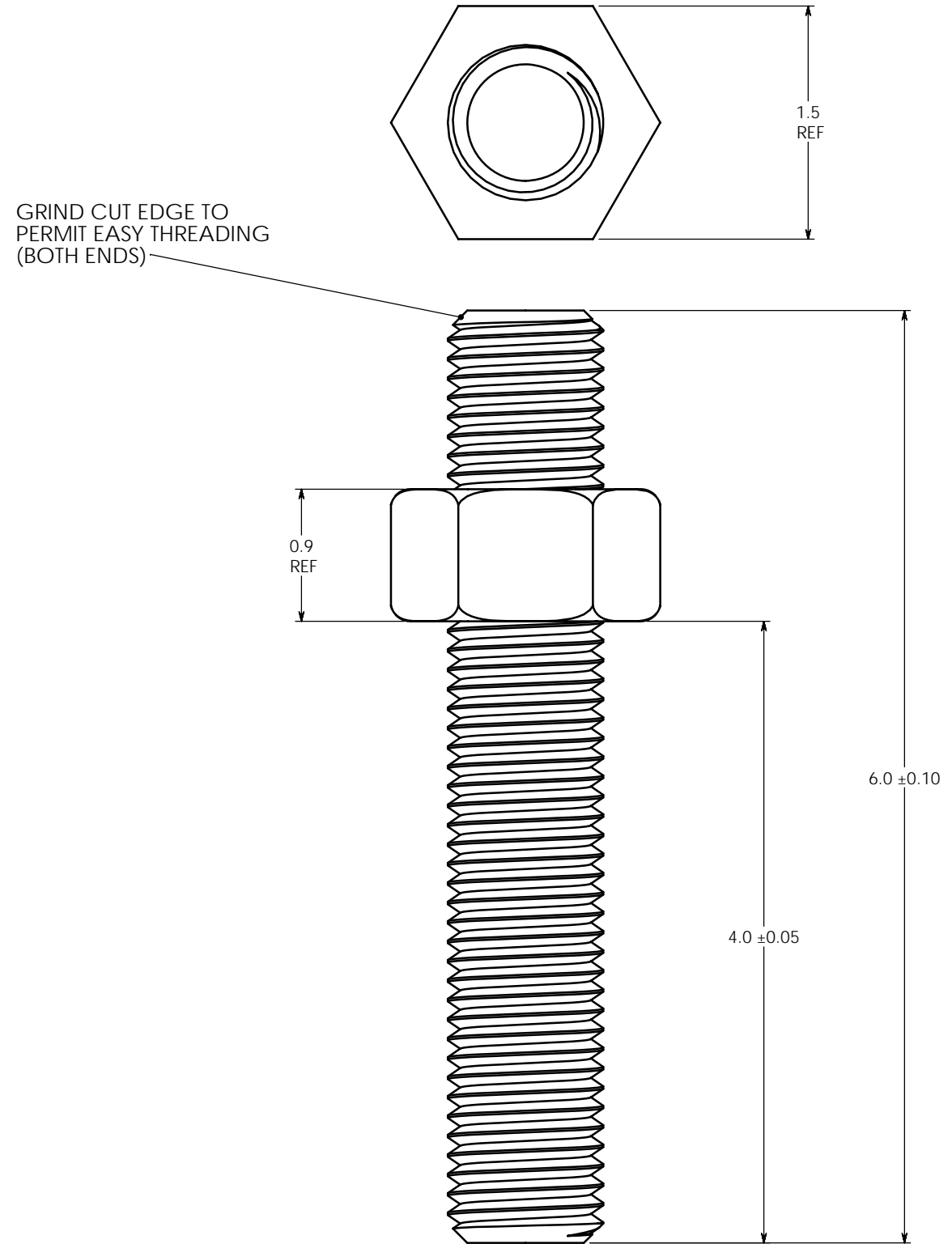

HEX NUT, FINISHED
1" x 8 UNC THREAD

QTY: ASPER RFQ

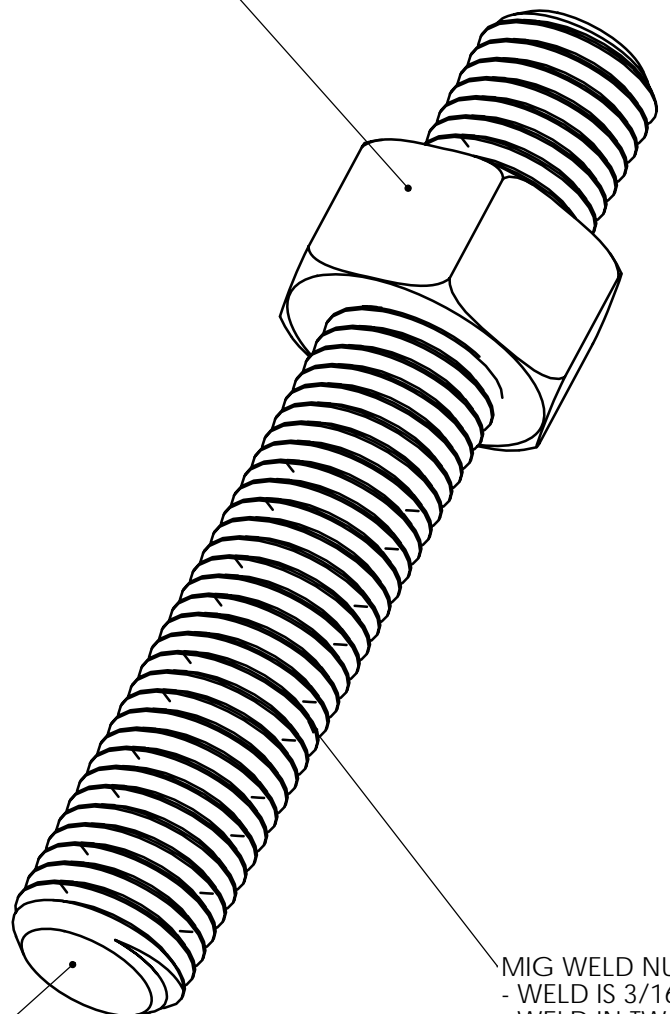

THREADED ROD
1" x 8 UNC THREAD

MIG WELD NUT TO ROD
- WELD IS 3/16" FILLET WELD x 1/2" LONG
- WELD IN TWO PLACES, 180 DEG APART

PROPRIETARY AND CONFIDENTIAL
THE INFORMATION CONTAINED IN THIS DRAWING IS THE SOLE PROPERTY OF TELAJACK LLC. ANY REPRODUCTION OR DISTRIBUTION IN PART OR AS A WHOLE WITHOUT THE WRITTEN PERMISSION OF TELAJACK LLC IS PROHIBITED

UNLESS OTHERWISE SPECIFIED:

DIMENSIONS ARE IN INCHES

TOLERANCES:

FRACTIONAL	± 1/32"
ANGLE	MACH ± 0.25° BEND ± 0.5°
TWO PLACE DECIMAL	± 0.03"
THREE PLACE DECIMAL	± 0.010"

DATE:	2007.04.10	NAME:	A BUTLER	CUSTOMER:	PCT
DRAWN:				PART NO:	04
CHECKED:				DESCRIPTION:	THREADED ROD ASLY
ENG APPR:				MATERIAL:	STEEL
MFG APPR:				FINISH:	ZINC DICHROMATE PLATED
QA APPR:					
COMMENT:	ASSEMBLY TO BE PLATED AFTER WELDING				

TELAJACK

DRAWING NO:
RFQ01-M-04-REV 0

WEIGHT: 1.45 LBS

ISSUED: 12/31/2007